

APECS® / AP CYLINDER



OFFERING THE MAXIMUM LEVEL OF SECURITY FOR ENTRANCE DOORS

The APECS AP is our BSI 3 Star Kitemark, Sold Secure Diamond Standard Cylinder which offers maximum protection. It safeguards from all forced methods of attack ranging from snapping, drilling, plug-extraction, picking and bumping.

The APECS AP cylinder is specifically designed to protect from unauthorised access by burglars. The AP cylinder is engineered with a unique sacrificial point, which when tampered with externally sets an interlocking cam mechanism into action, preventing any further damage to the internal parts of the cylinder, whilst still keeping the lock operable from the inside.

In the event of snapping, the home owner can still operate the door and exit the property due to the lock's unique mechanism which is engaged when the cylinders external section is snapped off. This mechanism slides the clutch into place, preventing further external damage and manipulation of the cam, whilst keeping the lock operable from the inside.

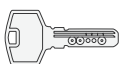
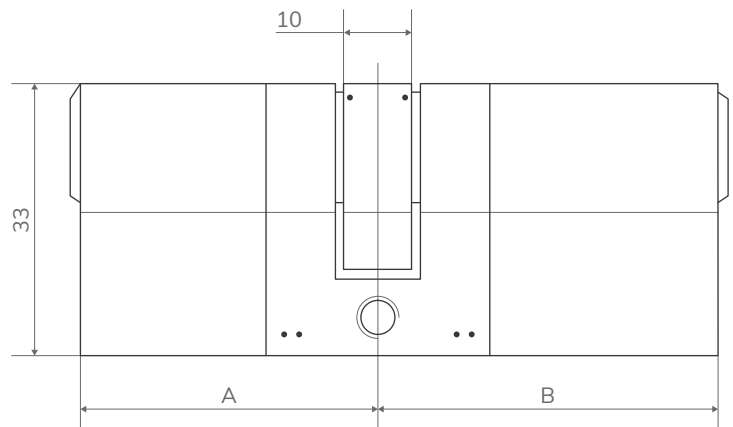

DIMPLE KEY

Material	Brass/Hardened Carbon Steel
Mechanism type	Pin tumbler
Effective differs	In excess of 180,000
Number of pins	9
Sizes	70-110mm and offsets
Variations	Key-Key & Thumbturn
Key type	Restricted profile dimple key
Number of keys	3/5
Finish	Brushed Brass/Brushed Satin Nickel

UNIQUE FEATURES

- Double locking mechanism with additional track rail pins
- Patent pending interlocking mechanism and hardened cam protection block prevents from snapping and plug extraction
- Patent pending ball-bearing connection ensures additional operation smoothness and strong fixing between the cylinder core and the cam
- Operable from inside when lock is tampered with externally
- Modular system for re-pinning, keying alike and master key systems

CERTIFICATES

- BSI 3 Star Kitemark – KM621947
- Sold Secure Diamond Standard – CLME08161454
- Tested to TS007:2014 A1:2015
- Tested to EN1303:2015 — 160B0C6D

SECURITY INFORMATION

- Anti-pick: 4 pins on each side
- Anti-bump: double locking mechanism with track rail pins in combination with a unique shallow chamber
- Anti-drill: 2 pins on each side of the cylinder shell + 5 on each side in the cylinder core
- 1 steel driver pin on each side
- Snap-secure sacrificial point
- Restricted key profile
- 10-year guarantee
- 5-year snap-secure guarantee

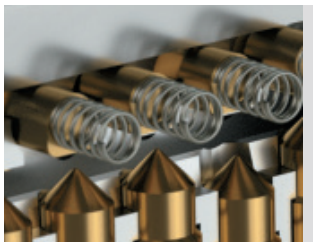

Double locking mechanism with track pins offers maximum protection from bumping and picking



Snap secure sacrificial point

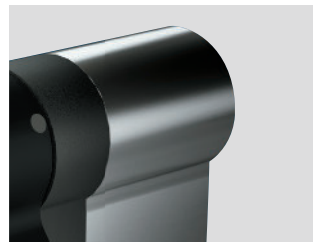

Operable from internal side when lock is tampered with externally

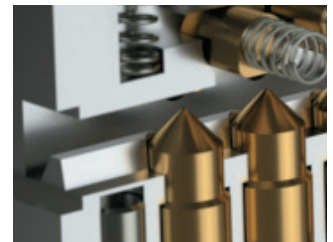

Anti-plug extraction



Drilling attack resistance: Hardened Steel pins in the cylinder core and body



Hardened Steel cam protection block prevents snapping and plug extraction



Interlocking mechanism engages when the external side is snapped

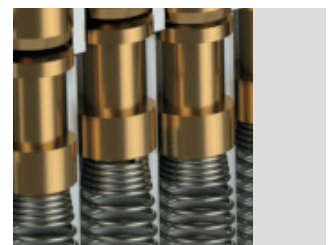

Anti-pick protection: special grooved pins