

The Ultimate Doors and Windows

Installation Guide

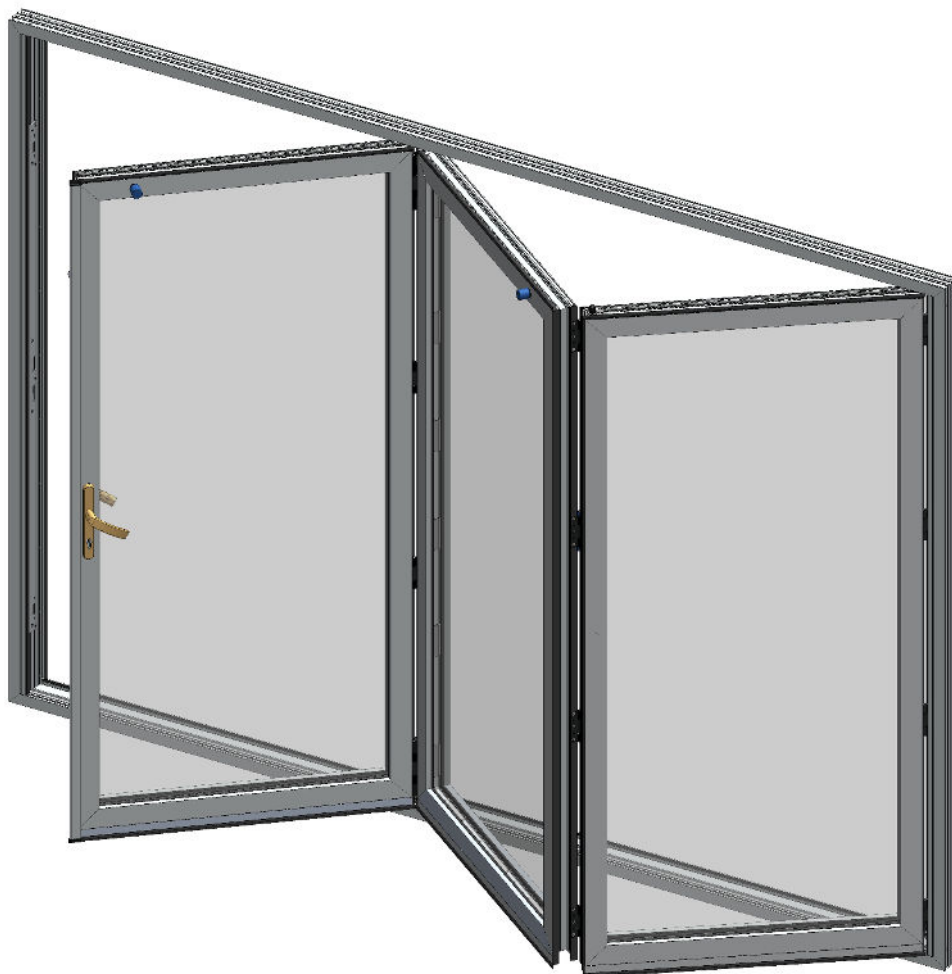

INDEX

1. SITE SURVEY	3
• Opening inspection	3
• Internal finished floor level and datum line position	3
2. DIMENSIONS	4
• Standard Weather Rated Threshold/Track with Cill	4
• Internal Low (NOT WEATHER RATED) Threshold with Optional Ramp & Rebate	5
• Part Names	6
3. INSTALLATION	8
• Cill installation	8
• Outer frame installation	9
• KIT FORM	10
○ Door leaf installation	10
○ Sliding post installation	13
○ Operation checking and adjustment	14
• Master door adjustment	15
• Width adjustment using adjustable jambs	15
• Securing hinges with final fixing screws	16
4. GLAZING INSTRUCTIONS	17
• 'Toe & Heel'	17
5. OPERATION CHECKING AND ADJUSTMENT	18
• Panel catch/magnet installation	18
6. FINISHING TOUCHES	19
7. OPERATION AND MAINTENANCE	19
• Opening and closing operation for bi-folding door with swinging door	20
• Opening and closing operation for bi-folding door without swinging door	20
• Maintenance recommendations	21

SITE SURVEY

Opening inspection

- The aperture for the new doors must be flat, level, straight, plumb and square at every single side. There should be a solid structure to fix the frame.
- The aperture load bearings must not be transferred to any part of the frame when fitted.
- Prepare the aperture by making sure it is clean.
- Remove any old silicone and brush down the threshold.
- The internal and external reveal sizes should be checked and any variations must be determined to ensure enough opening light for the area where doors will fold and will not be obstructed by plaster, tiles or etc.
- Check the aperture’s height, width and diagonals to ensure the opening is equal on all sides and square.
- Generally three measurements should be taken.

NOTE: The smallest measurement of width and height used to determine manufacturing sizes.

- See Also Section “Aperture height using laser level.

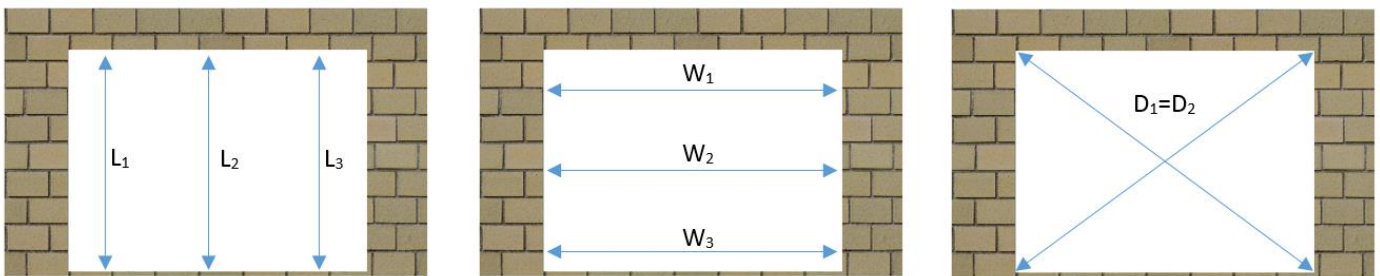

- Use tape measure to verify the aperture overall height and width. At least three measurements must be taken.
- Smallest height and width measurement will determine the overall frame manufacturing size.
- By measuring the diagonals verify the aperture is square.

NOTE: Must allow minimum 10mm tolerance between your opening size and the frame sizes for manufacturing

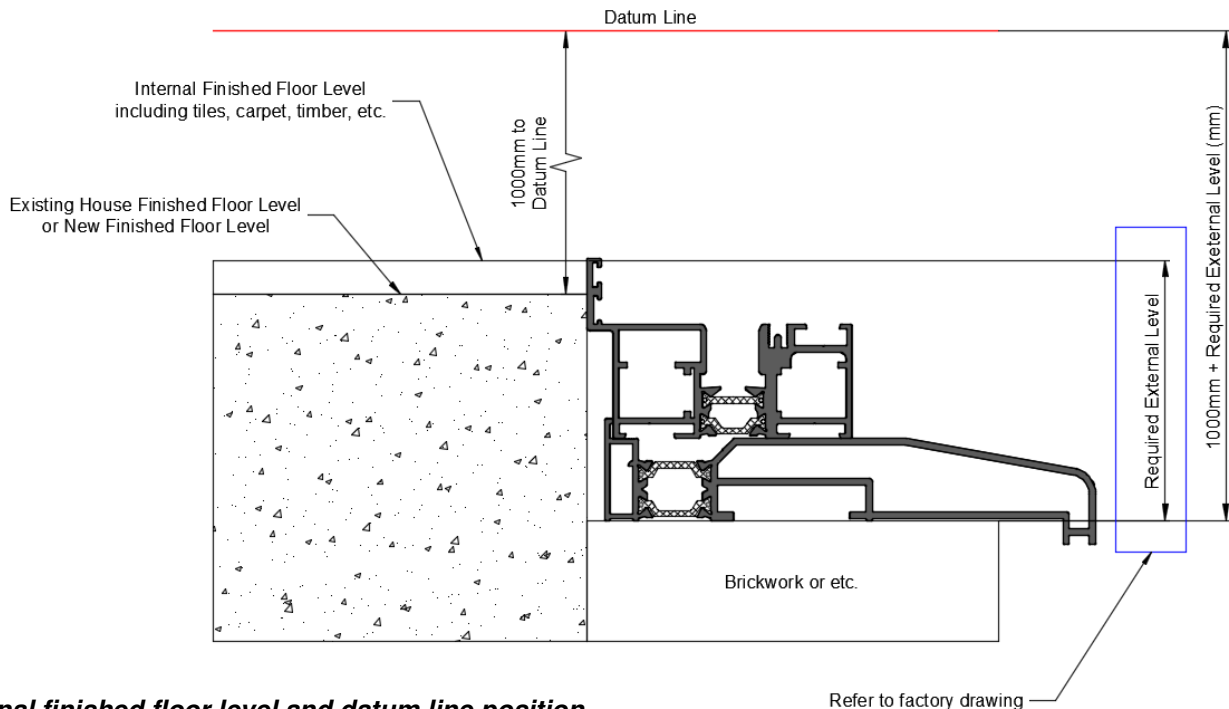

Internal finished floor level and datum line position

- Select a point within the agreed/existing structure finished floor level from where the builder can after determine the internal floor level i.e. tiles, carpet, timber.
- Using laser measure set a datum line at 1000mm from the existing finished floor level.
- Take into account the agreed internal floor finish i.e. tiles, carpet, timber.
- Mark the datum line on each jamb of the aperture.

DIMENSIONS

Standard Weather Rated Threshold/Track with Cill

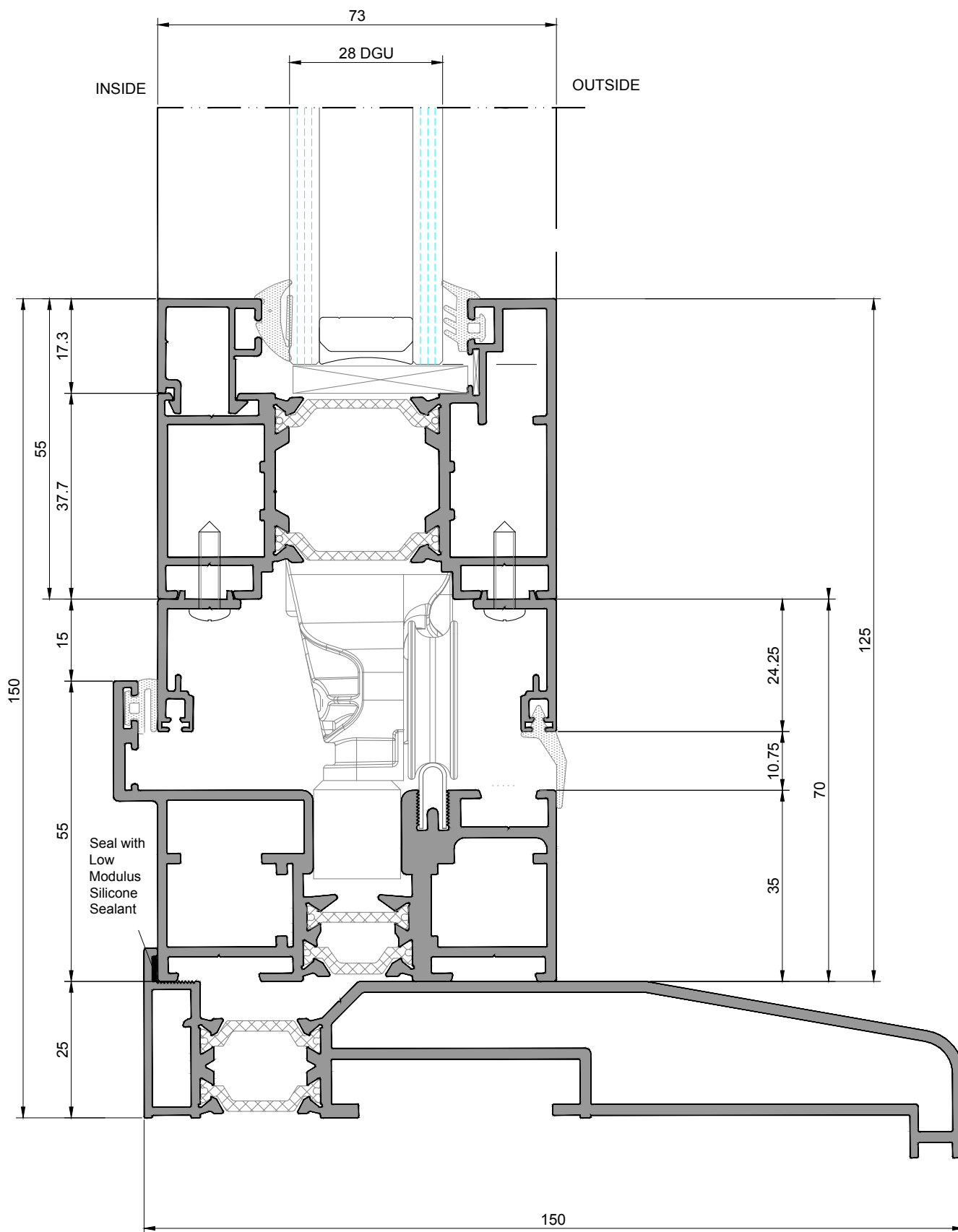

DIMENSIONS

Internal Low (NOT WEATHER RATED) Threshold with Optional Ramp & Rebate
Only Available in Silver Anodised

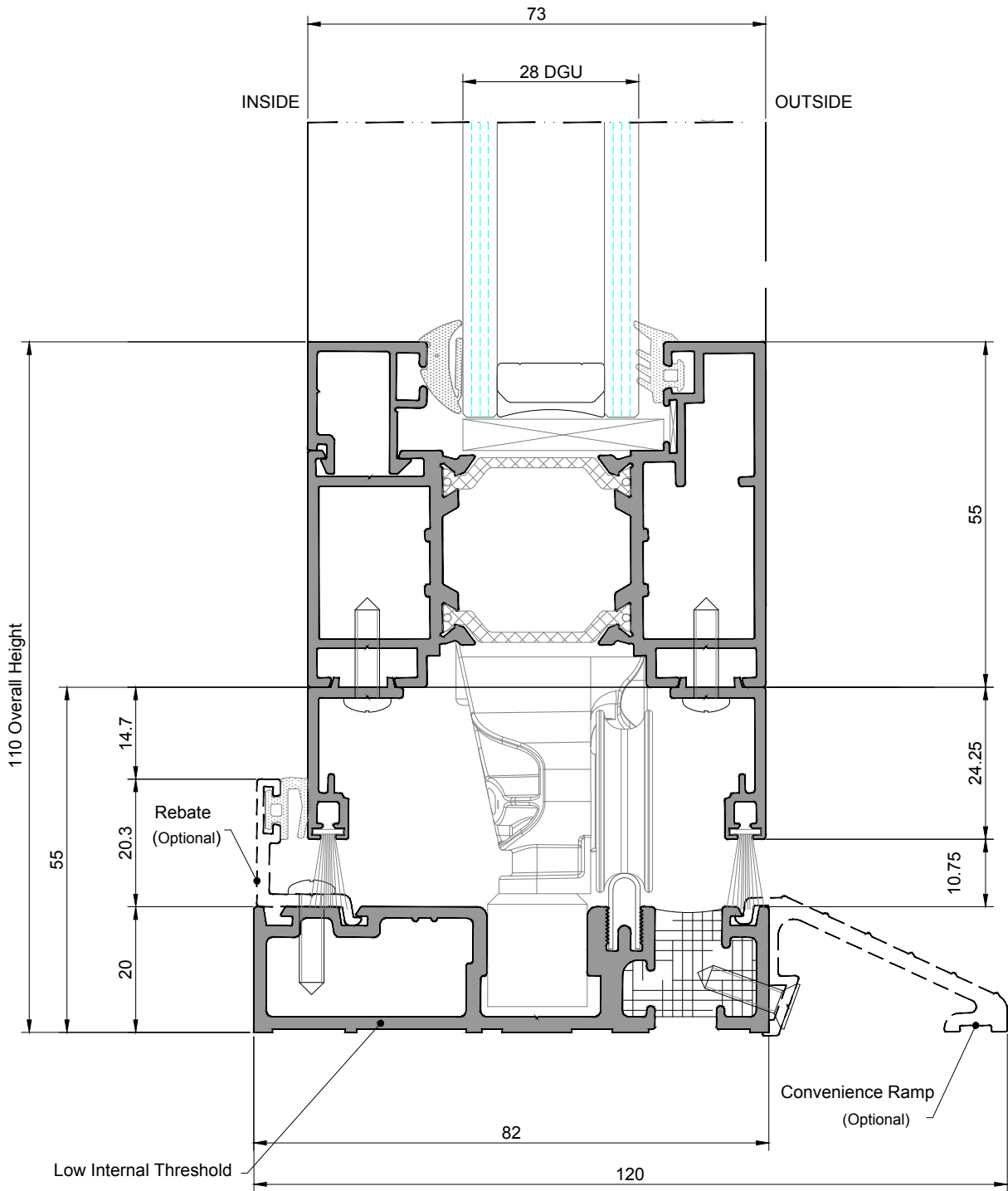

PART NAMES

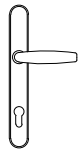

Master handle
Lever / Lever



Shootbolt handle



Shootbolt handle with escutcheon

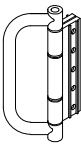

Pull handle / D-Handle
hinge with fixings
(open in or open out)

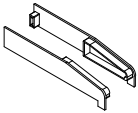

150mm Sill end caps

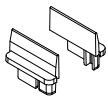

Rebate end caps



Bottom horizontal seal



Top horizontal seal



Vertical sash seal 5.5mm



Vertical sash seal 8mm



Cover gasket



Captive glazing seal / E gasket



Wedge glazing seal



Rebate seal



Outer frame seal



Outer frame weatherpile



Low level Sill fin weatherpile

PART NAMES

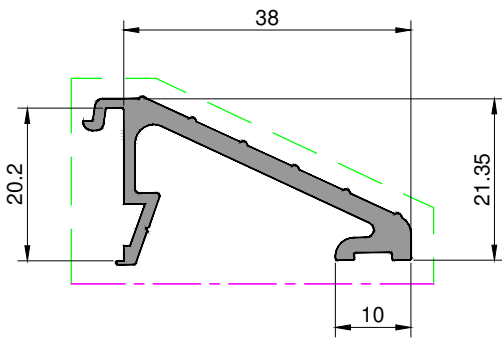

Low Threshold
convenience
Ramp Add-On

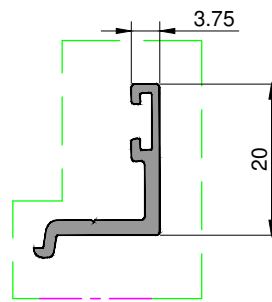

Low Threshold
Rebate Add-On

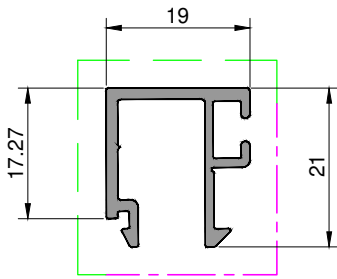

Glazing Bead
For 28mm Double Glazed Units

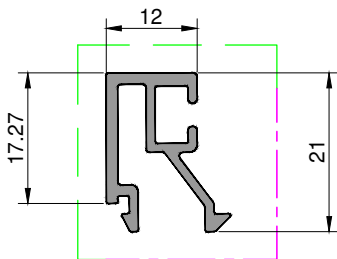

Glazing Bead
For 35mm Triple Glazed Units

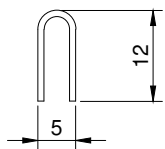

Running Track

CILL INSTALLATION

- The need for any cill should be determined at the beginning of the project.
- The size of the cill should be as such that there is an overhang of at least 25 mm from the face of the building.
- The installer should determine how the cill should be fitted, taking into account features such as horns.

Cill installation

NOTE: - Check the cill for drainage slots, make sure they are clean and not blocked by any debris, clean if necessary.

- 1) Using low modulus silicone seal the ends of the cill section
- 2) Install the end caps as shown below
- 3) After fixing end caps, add silicone as shown in red below, onto the thermal break

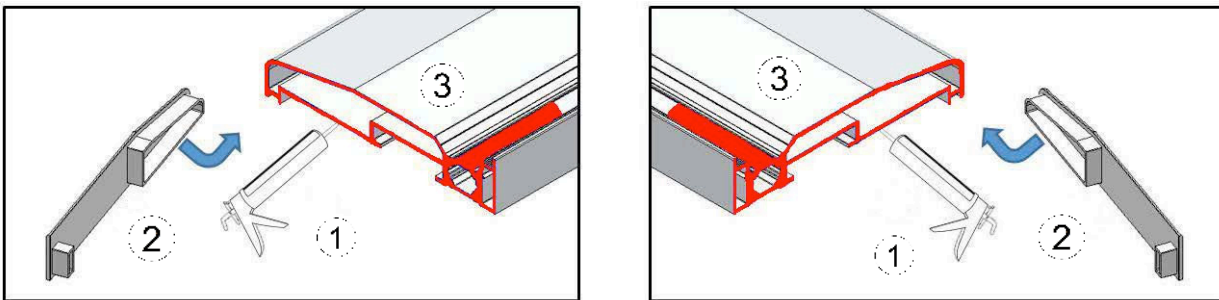

- Place the cill on to the aperture
- Use a spirit/laser level or a string line to assess the level of the cill
- Temporarily place the required packers under the cill, check the level and adjust if necessary

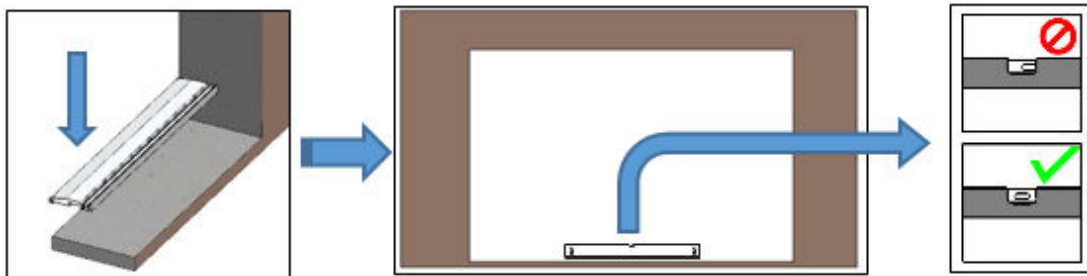

- Apply silicone to the floor and fix the cill into position. As indicated in red below.

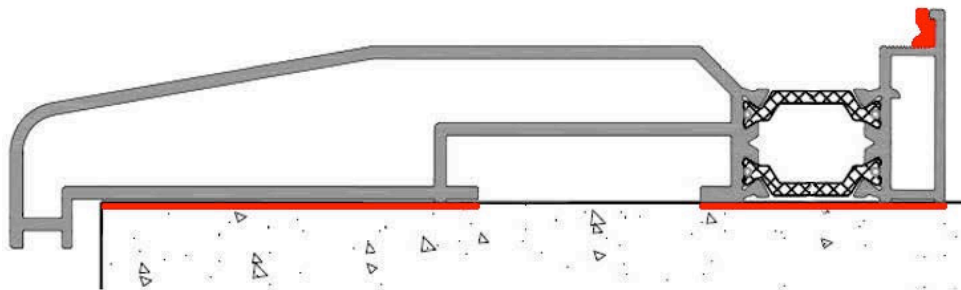

- Double check for level and adjust if necessary.

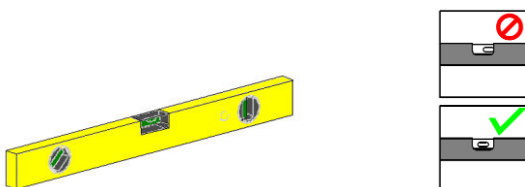

Outer frame installation

- Insert the frame into prepared structural opening and pack as necessary to ensure that the frame is held plumb and square inside the opening.

NOTE: - If cill installed. Run a silicone bead along the cill rebate to ensure weather tight joint.

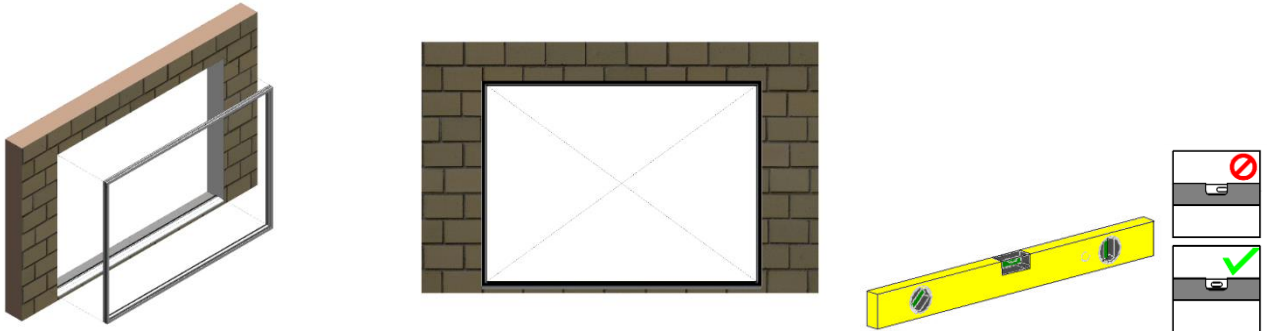

- Pack out all fixing points to ensure tight and supported fixings.
- Secure frame using suitable fixing screws and plugs.
 - A = Anchor distance from corner of frame approximately 150mm.
 - B = Anchor spacing generally at maximum 500 mm.
- Ensure the top and bottom frame remain plumb and square over the complete length.

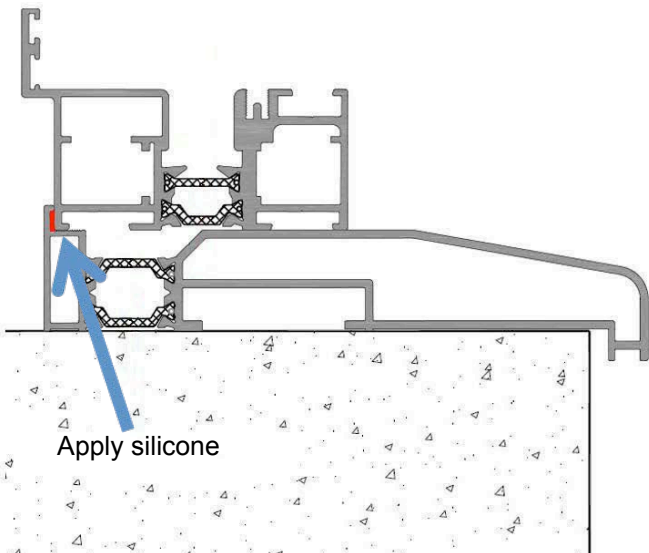
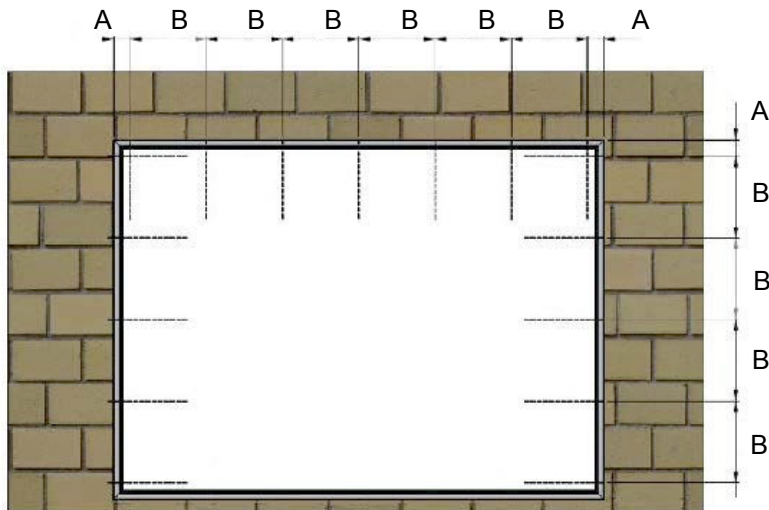

Typical outer frame installation with cill

- Check the level and make sure that the frame is set plumb and square.
- Using low modulus silicone ensure that the perimeter is sealed against water penetration at both inside and outside of the opening.
- Clean away all debris from bottom rail, especially guide channel.

DOOR LEAF INSTALLATION

General installation recommendations

- Before installing any door panels check for all the components. Make sure there is no missing components.
- Look for the panel glass beads to determine the interior side.
- Look for the panel drainage holes to determine the bottom side.
- All panels are numbered and must be installed with accordance to the factory drawing.

Panel No.1 Installation

- Align the side of panel No.1 that has clamping plates on with hinges attached to outer frame adjustable jamb.

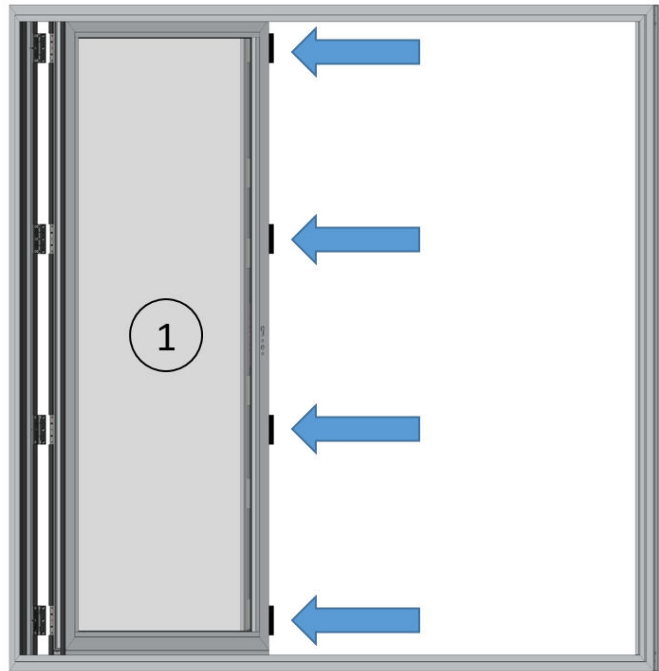

- Locate the hinge leaf over the clamping plate and secure with M5x10mm machine screws using top and bottom countersunk hinge holes.

TOOL REQUIREMENT: - 3mm Allen key is required.

NOTE: - Do not use 4.2x25mm self drilling screws at this point.

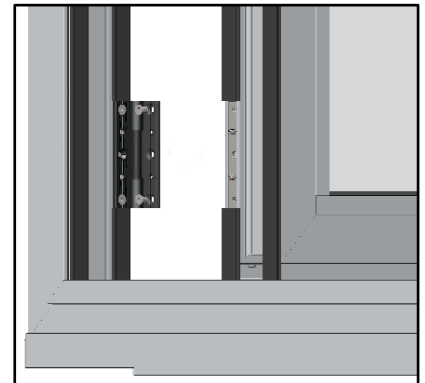
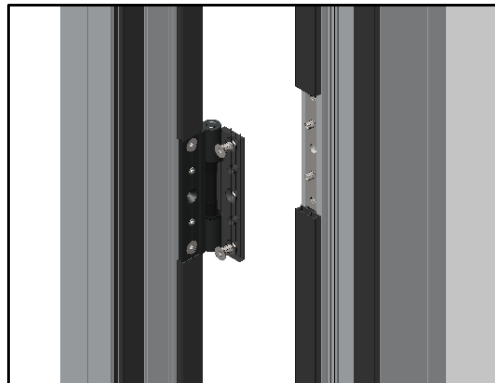
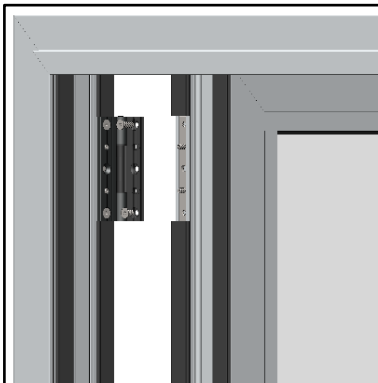

Panel No.2 Installation

- Slightly lean panel No.2 and fit the bottom roller guides into middle channel of the bottom track.
- Align the top guides of panel No.2 and fit them into middle channel at the top.

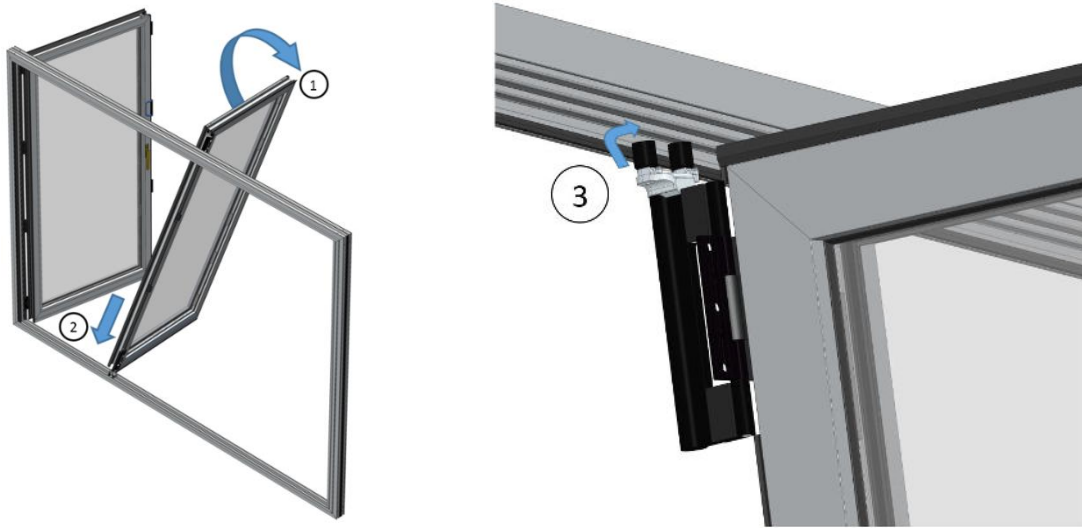

- Slide panel No.2 to align clamping plates with hinges attached to the first panel.
- Keep both doors on an angle for better access to hinges.

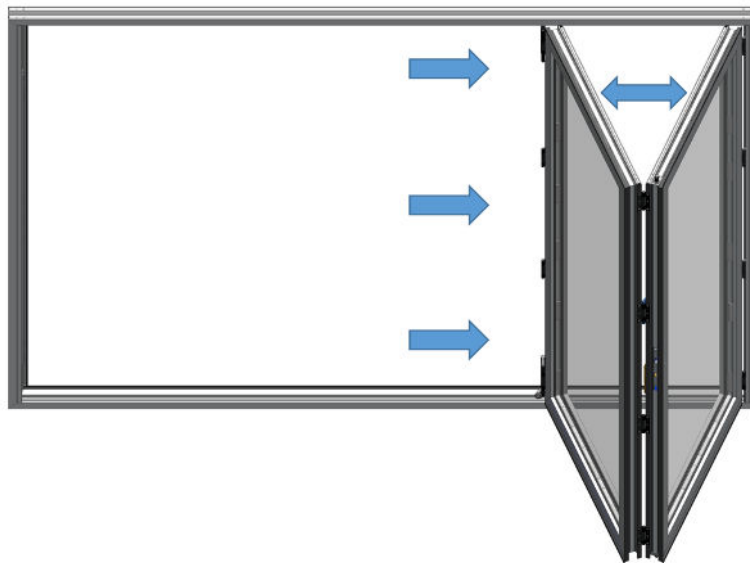

- Locate the hinge leaf over the fixing plate and secure with M5x10mm machine screws at top and bottom holes.

TOOL REQUIREMENT: - 3mm Allen key is required.

NOTE: - Do not use 4.2x25mm self drilling screws at this point.

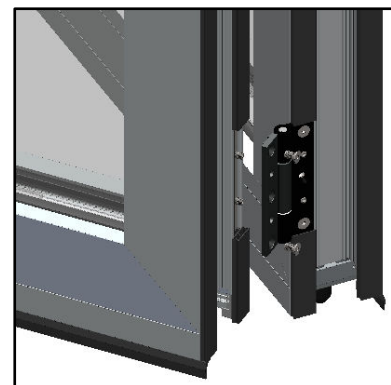
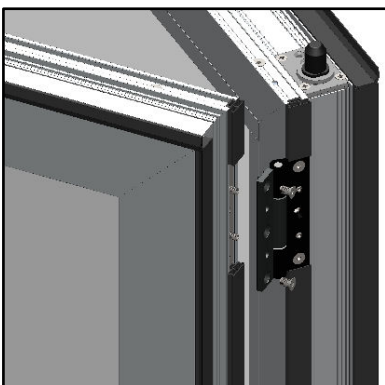

Panel No.3 Installation

- Lock first two panel doors together before installing door No.3.

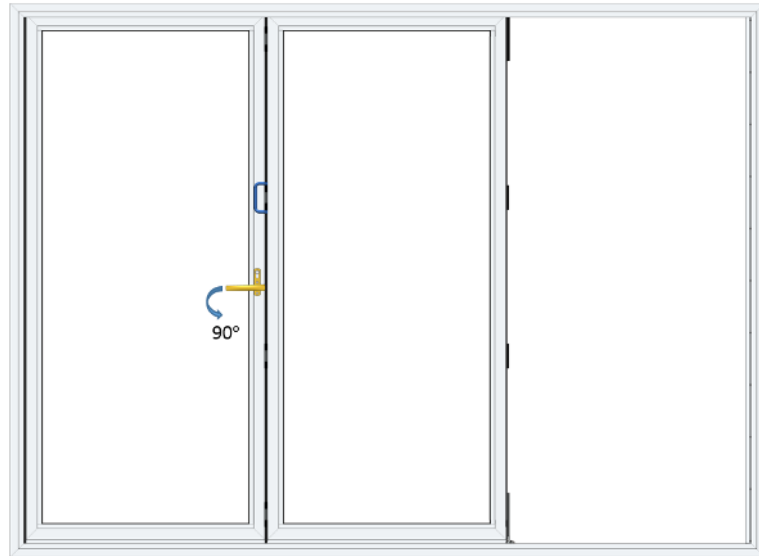

- Align panel No.3 clamping plates with hinges attached to second panel.

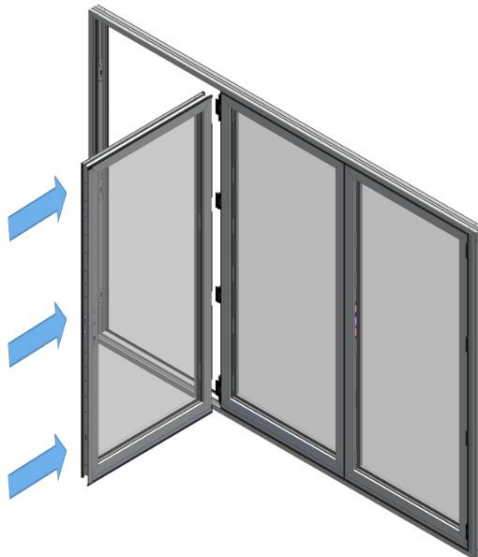

- Locate the hinge leaf over the fixing plate and secure with M5x10mm machine screws at top and bottom position.

TOOL REQUIREMENT: - 3mm Allen key is required.

NOTE: - Do not use 4.2x25mm self drilling screws at this point.

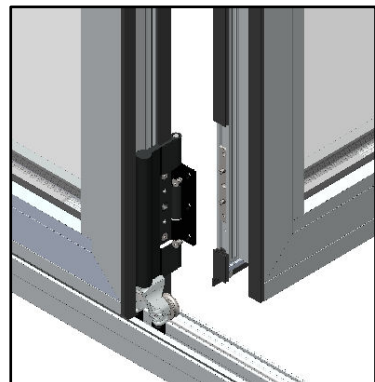
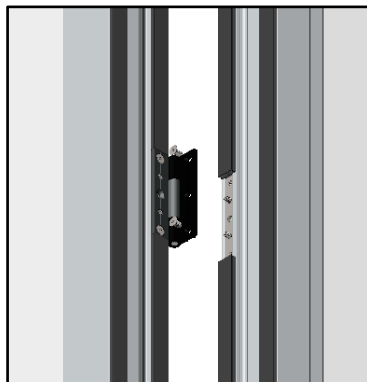
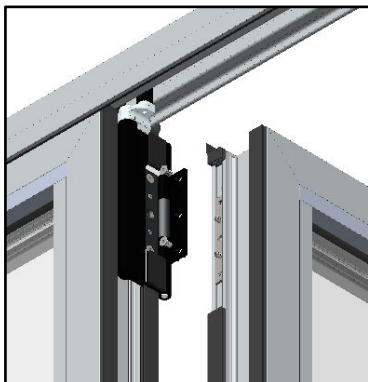

Sliding post installation

- Open the sliding post attached to the door panel as shown below.

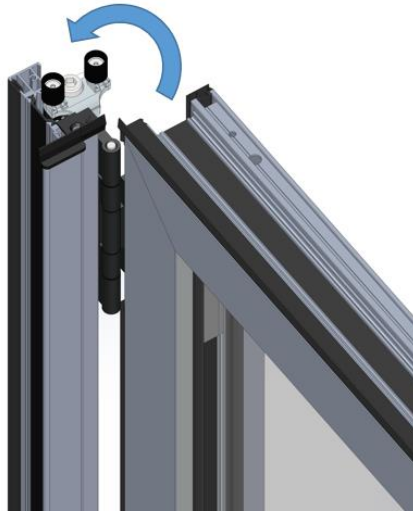

- Slightly lean the panel with sliding post and fit the bottom roller guides into middle channel of the bottom track.
- Align the top guides of panel with sliding post and fit them into middle channel at the top.
- Slide the panel to align clamping plates with hinges attached to the first panel.
- Keep both doors on an angle for better access to hinges.

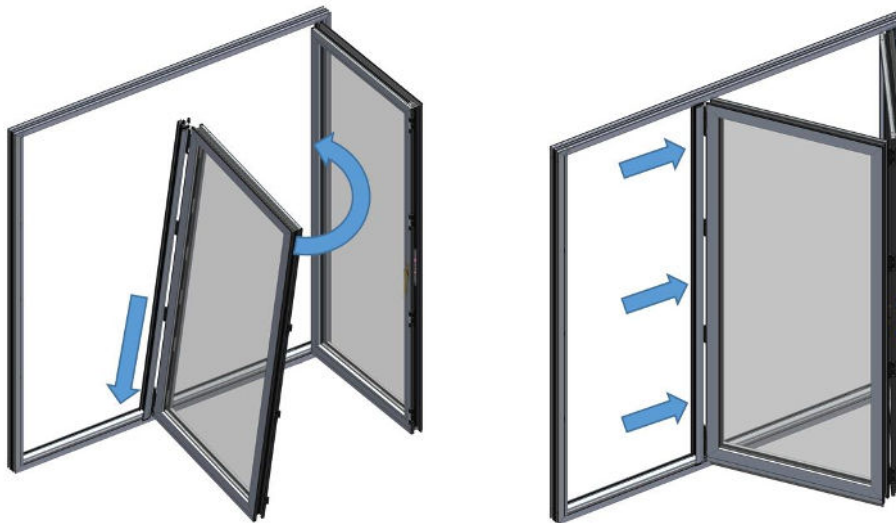

- Locate the hinge leaf over the fixing plate and secure with M5x10mm machine screws at top and bottom holes.

TOOL REQUIREMENT: - 3mm Allen key is required.

NOTE: - Do not use 4.2x25mm self drilling screws at this point.

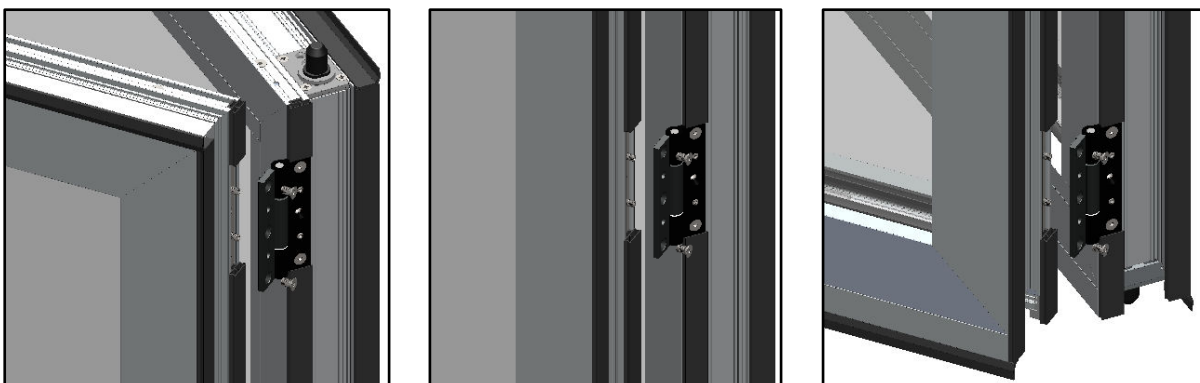

OPERATION CHECKING AND ADJUSTMENT

Door unit operation inspection

- Check the basic running operation of the doors to make sure the mechanisms are working properly.

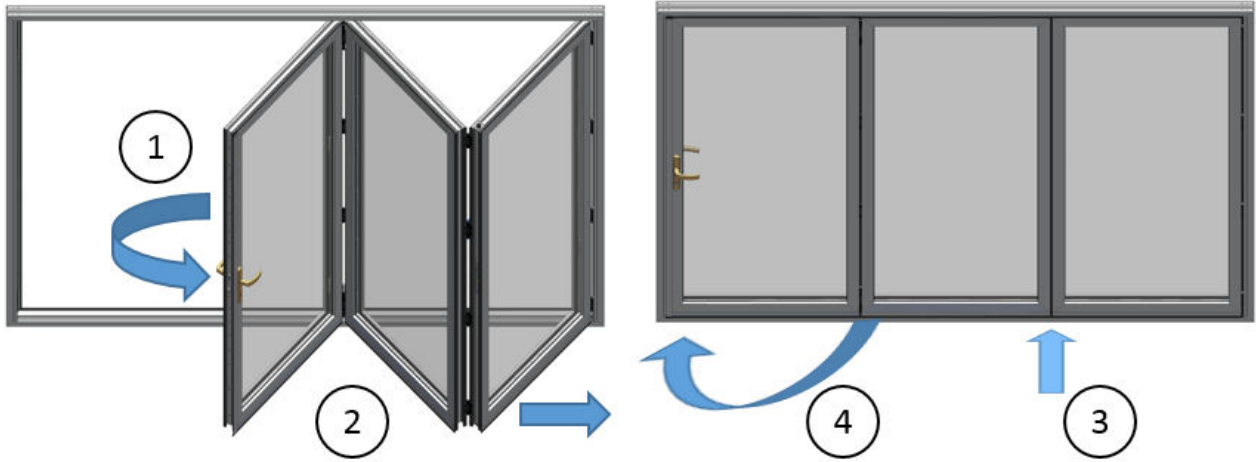

Overall gap size inspection

- Assess the horizontal gaps between the outer frame and sash at the top and bottom ensuring they are even and equal to 11mm.
- Assess the vertical gaps between the panel frames ensuring they are even and equal to 10mm.

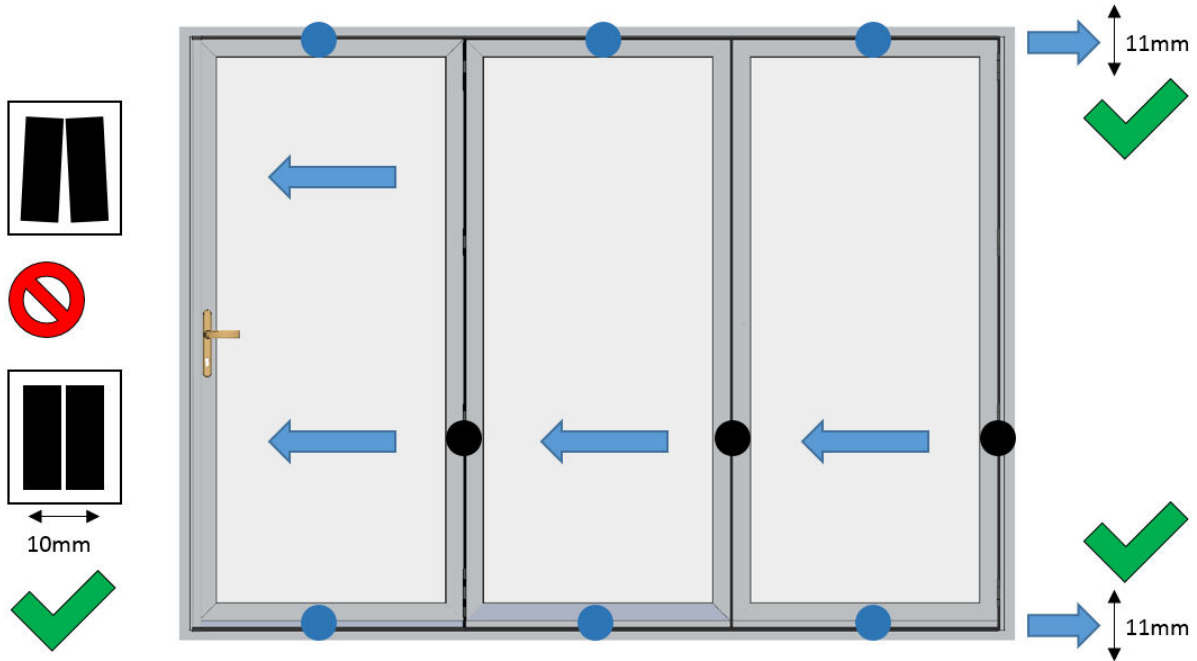

Master door adjustment

- Remove the rebate profile attached to the master door to see the gap where the lock and the keep are.
- Check the distance between the locking door and the outer frame. The distance should be 13mm.

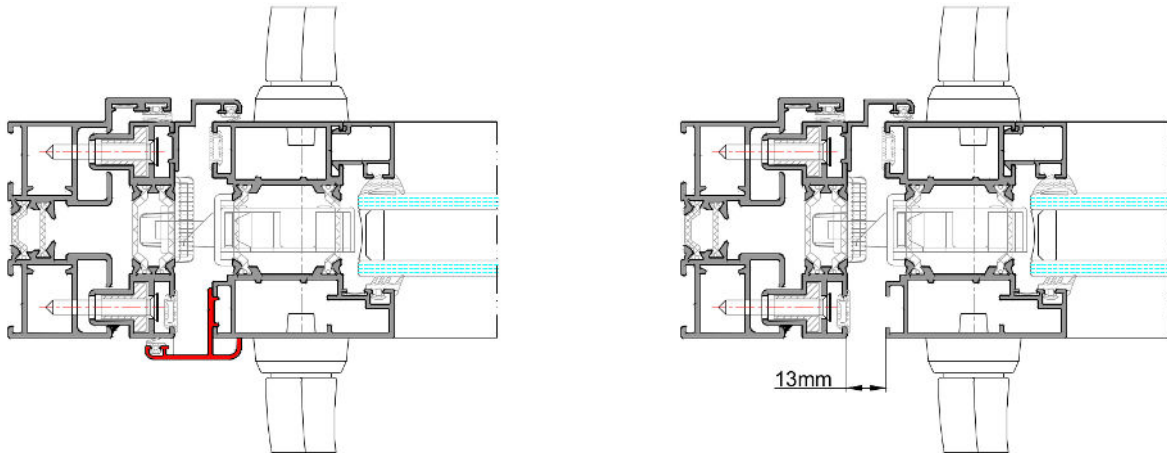

- If the lock and keep are clashing regulate the distance by adjusting adjustable jambs as shown below.
- Once the correct gap is achieved and the lock is locking perfectly fix the rebate profile back on the master door panel.
- Double check if the lock is latching properly.

Width adjustment using adjustable jambs

- To adjust the width release all bottom self-tapping screws that secures the adjustable jamb.
- Use grub screws to change the position of the adjustable jamb.
- Check the gaps to be equal and adjustable jamb is set square and level.
- After completing adjustment fix the adjustable jamb in position by securing self-tapping screws.



- Adjustable jamb is designed to have both positive and negative adjustment as shown below.

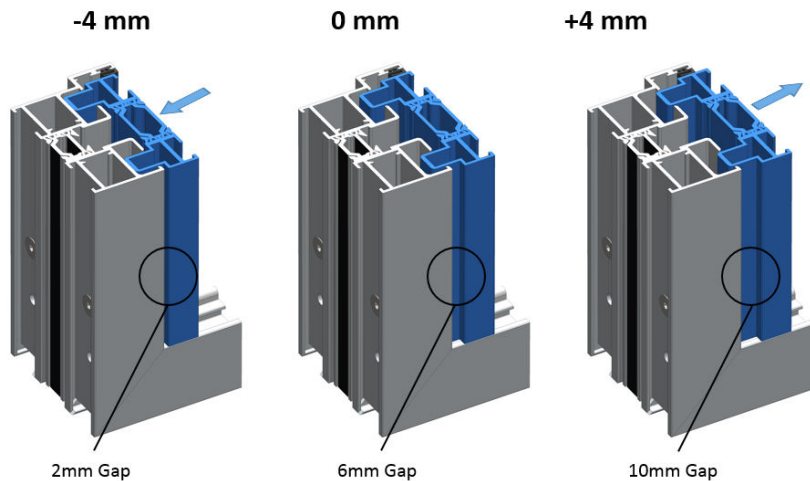

Securing hinges with final fixing screws

- After completing the installation and the doors operate properly, ensure to secure ALL hinges with final fixing screws as shown below. Then proceed to glazing.

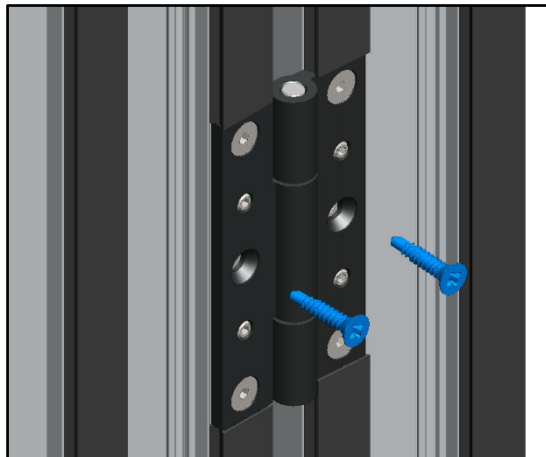

Weather seal application

- Apply missing or any removed weather seals on all panels and jambs. Ensure that the ribbed part of the seal would always be installed facing inner part of the profile.

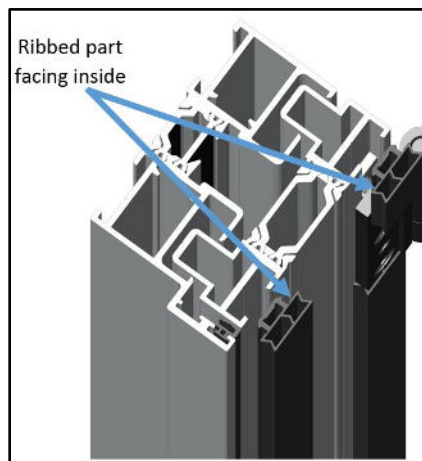
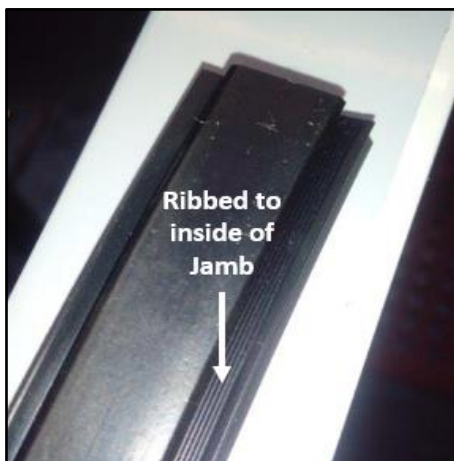

GLAZING INSTRUCTIONS

NOTE: - All glazing should conform in the requirements of BS 6262. In addition any instructions given by glass manufacturers should be followed.

- Before glazing, lock all doors panels and fully engage the locks.
- Starting from the first panel hinged to the jamb remove all beads, taking care to note where the beads are removed.

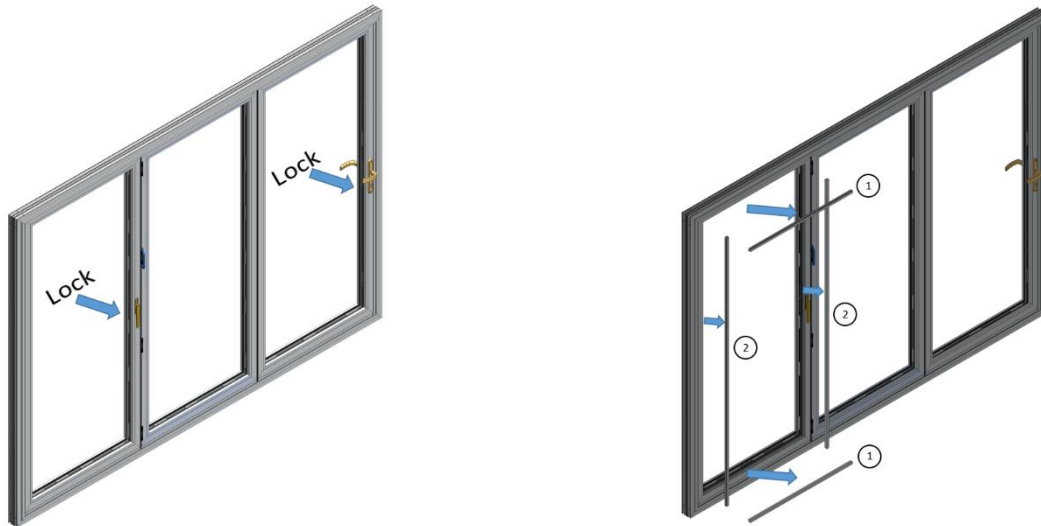

- Install the glass into the frame and pack it appropriately using various thickness glass setting blocks. Ensure to support inner and outer layers of the glass.
- All panels should be 'toe and heeled' to maintain equal and parallel gaps between outer frame and panel at the top and bottom.
- Add silicone between each vertical set of packers to help keep them in place. Make sure that all packers do not obstruct any of the drainage or decompression holes.

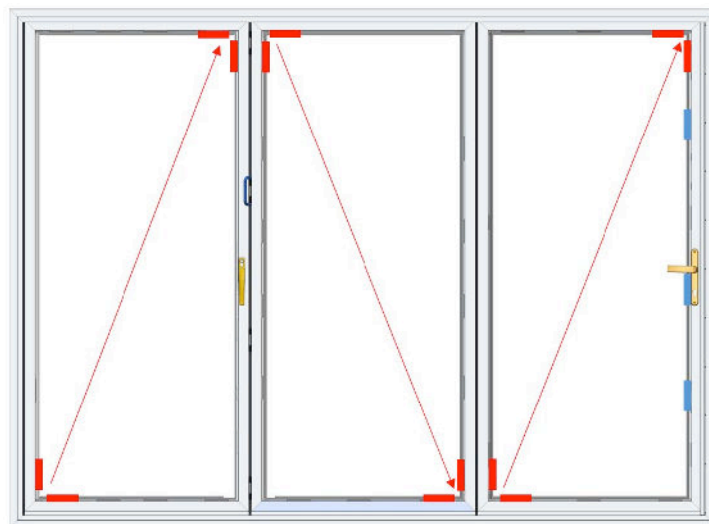

- 'Toe and Heel'. Load caring packer must be used to keep panels square and level.

- Supporting packers - Locking onto the keep on master door

- Replace beading, starting with shortest pieces first and tapping into place with a plastic mallet.
- Replace wedge gaskets into position.
- Repeat the 'toe and heeling' process for all panels, ensuring that all door gaps are equal and parallel.
- Check for door running operation and adjust if necessary.

Panel catch installation

- Position the swing door at the point where it will stop.
- Ensure some clearance between the lever handle and next door.
- Use fully assembled panel catch pair to locate the position between two doors.
- Mark with pencil the position for panel catch on swinging door first.

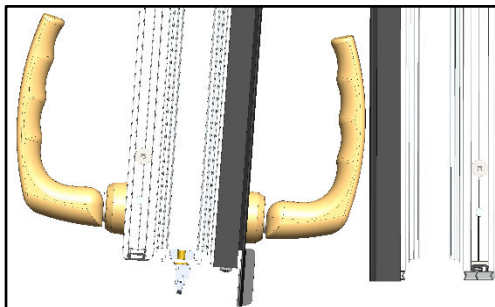

1. Position the door

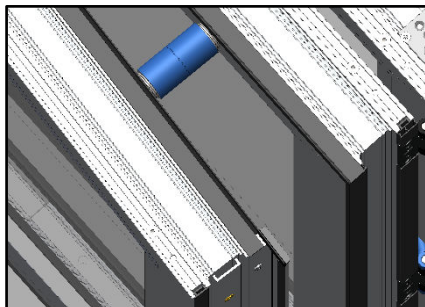

2. Locate panel catch

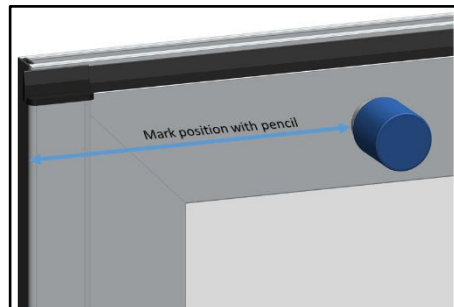

3. Mark position on swing door

- Unscrew panel catch back plate and fix it with choice of fixings provided in the box.
- Ensure the position for anti-rotation screw is pointed towards the hinge side.
- Secure the 3mm pointed anti rotation grub screw.
- Screw the outer sleeve.

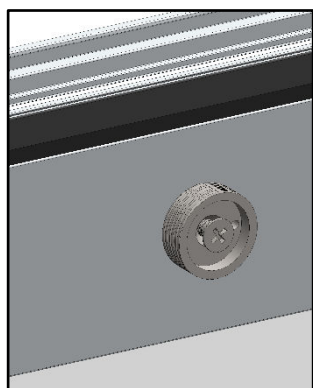

4. Fix the plate



5. Position anti-rotation point

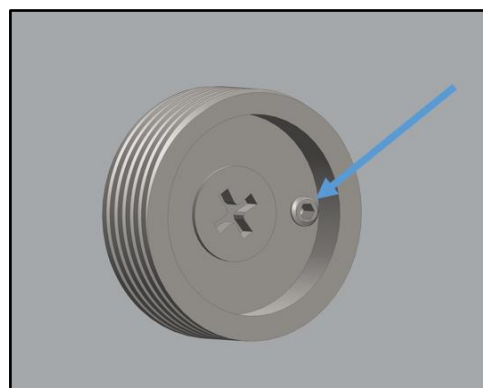

6. Fix anti-rotation screw

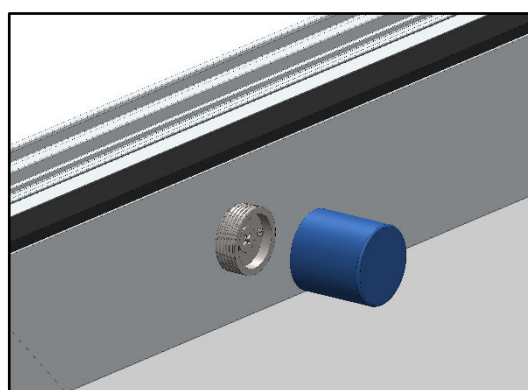

7. Screw the outer sleeve

- Mark the perfect position for panel catch on the opposite panel.
- Ensure anti rotation screw is pointed to the nearest swinging door hinge.
- Fix the second panel catch by repeating steps 4 - 7

FINISHING TOUCHES

- Check that the handles and locking mechanisms operate smoothly on each door.
- Check the bi-fold action is smooth and free running.
- Check that the locks operate correctly when closed.
- Check the door magnets are fully engaged when the doors are open.
- Check the hinges and ensure that there are no screws missing.
- Check the weather seal and ensure that the doors are fully sealed.
- Check the perimeter and ensure that the door unit is weather tight.
- Clean the bottom track and ensure it is free of any debris.
- Ensure that the homeowner is instructed and knows exactly how to use and look after bi-fold doors.

HOMEOWNER INSTRUCTIONS FOR BI-FOLD DOOR USAGE

GUIDANCE FOR OPERATING YOUR DOORS

- Ensure the doors are always opened and closed in the correct sequence as per the instructions overleaf.
- If there is an internal key operated cylinder fitted on the intermediate doors, the key must **NOT** be left in situ as it will break the key and mark the profile.
- To ensure correct operation of the multi point latch lock, make certain that the handle is lifted upwards to engage the hook bolts before locking the cylinder.

GENERAL MAINTENANCE ADVICE

Ensure all tracks, running channels and draining holes are kept clear of debris. Regularly wash the profiles and gaskets with warm soapy water. For coastal locations this should be done on a more regular frequent basis.

YEARLY MAINTENANCE

Clean the stainless steel track and rollers with a dry clean cloth. Apply lubrication oil to all hinges and rollers. Addition regular maintenance may be required in the following situations;

- Doors fitted on business premises that have a higher volume of operation per annum.
- If the doors have not been operated for an extended period of time.
- When doors are in extreme weather locations, for example coastal environments.

OPERATION AND MAINTENANCE

Opening and closing operation for bi-folding door with swinging door

To open doors

- Open the swinging door and connect it to the panel catch located on the next door.
- Release the shoot bolt locks on all other panels.
- Slide the folding panels starting from the pair nearest to the swinging door.

To close doors

- Slide each pair of folding panels back to align with frame
- Secure the panels by locking with shoot bolt lock.
- Close the swinging door last, ensure that all other panels have been locked in frame first.

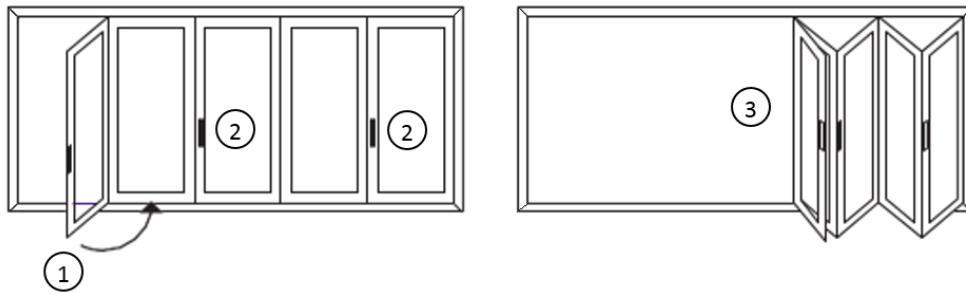

Opening and closing operation for bi-folding door without swinging door

To open doors

- Unlock the shoot bolt locks using the cylinder key if applicable.
- Turn the intermediate handles 90° to release the shoot bolt locks on all door panels.
- Ensure you **REMOVE THE KEY**, then slide each pair of folding panels away to one side.

To close doors

- Slide each pair of folding panels back to align with frame.
- Secure the panels by locking with shoot bolt lock.
- Use the key to secure the shoot bolt lock if applicable.

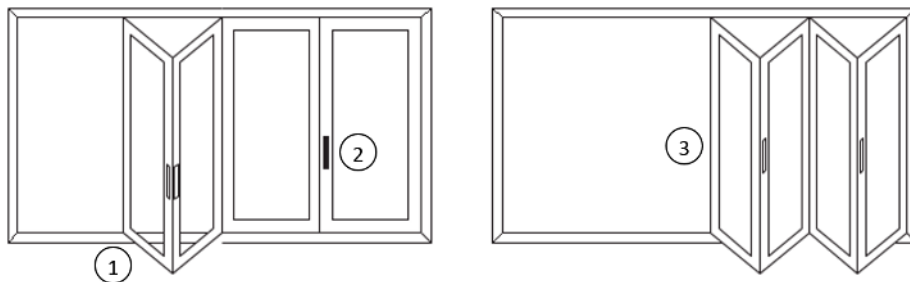

- Ensure top and bottom tracks are kept clean and free of any debris or foreign objects that can stop the function of the folding door.
- Ensure all door locking mechanisms are kept clean and any moving parts are regularly lubricated with light machine oil at least once a year.

NOTE: Use the D-handle located above the intermediate handle to assist pulling doors tight when operating shoot bolt lock.

WARNING: Do not leave the key inside the cylinder of the intermediate doors during sliding/folding operation as it can break the key or damage the profile surface finish.

OPERATING MULTI POINT LOCK ON SWING DOOR

TO LOCK THE DOOR

- Close the swing door, ensure that the door is latched properly.
- Turn the lever handle upwards to engage the lock hooks.
- Lock the door by turning the key cylinder twice.

MAINTENANCE

CLEANING MATERIALS

The following elements CAN be used:

- Warm water (with 2% of mild soap)
- Sponge
- Cleaning cloth
- Absorbent paper
- Steam cleaners
- Vacuum cleaner

WARNING: The following elements such as sharp tools (knives, trowels, etc.), steel wool or abrasive sponges, aggressive bath cleaners or solutions for lacquer must **NOT** be used, as they will cause permanent damage to surface area of the unit.

CLEANING OF CONCEALED AREAS

Use a vacuum cleaner to clean the gaskets and chambers between the sashes and frames to remove dust and other foreign matter. Ensure running track, channels and draining holes are clear of debris. A soft brush can be also used for cleaning.

It is recommended to repeat this operation frequently as required.

CLEANING OF FRAMES AND GLASS

Mix 2% soap solution to warm water to clean the frame and glass.

With a soft sponge wash the frames and glass to both inner and outer sides. Afterwards, using a cleaning cloth remove the remaining water drops and soap stains. Finally, with a dry cloth complete the cleaning and dry the frame.

Steam cleaner can also be used instead of soap solution.

It is recommended to repeat this operation monthly for each section.

MAINTENANCE RECOMMENDATIONS

Yearly:

Lubricate the stainless steel track, bottom wheel sets and all hinges with silicone based spray lubricant directly applying onto the moving parts.

Check for loose or missing screws and re-tighten or replace as needed.

KEY OBSERVATIONS

The maintenance should be increased:

- In areas close to highways, coastline or industrial areas.
- In business premises with a higher volume of operation per annum.
- When the doors have not been operated for extended periods of time.