

Winkhaus AV2 / AV2 E Automatic Locking System

Fabrication and Installation Manual
Timber and Composite doors



This security door locking system complies with the requirements and directives established and stipulated by the Council on the Harmonization of Legal Regulations of Member States regarding Electromagnetic Compatibility (89/336/EEC).

The manufacturer shall hereby certify the conformity of this product and document such by the CE marking (see Appendix).

Winkhaus STV GmbH & Co. KG

Berkeser Straße 6

D-98617 Meiningen

Germany

Tel.: +49(0)36 93/9 50-0

Fax: +49(0)36 93/9 50-1 34

www.winkhaus.de

The following information and graphic images provided correspond to the current status of the development and manufacture of this product.

For the purpose of customer satisfaction and operational reliability of the electronic automatic locking system, we reserve the right to make changes to this product.

All information and specifications given in this operating manual have been compiled and reviewed with utmost care.

Due to the nature of technical advances made, amendments to legal regulations and other compulsory changes we do not Guarantee for the accuracy and completeness of the contents' statements.

We always do appreciate suggestions or comments.

The electronic automatic locking system can be easily installed, if these operating instructions and the door specifications indicated have been followed.

© Winkhaus STV GmbH & Co. KG. All rights reserved. Last revised: 10/2006

Table of Contents

1	Fabrication Procedures	Page 4
1.1	Sash & Frame Preparation	Page 4
1.2	Hardware Installation	Page 4
1.3	Fabrication Final checks and adjustments	Page 5
2	Installation Procedures	Page 6
2.1	Installation Set Up	Page 6
2.2	Glazing	Page 6
2.3	General Door Set up	Page 7
2.4	Installation checks and adjustments	Page 7
3	Operating Instructions	Page 8
4	Routine Maintenance	Page 9
5	Troubleshooting Guides	Page 10
5.1	AV2 Locking System (automatic/manual)	Page 10
5.2	AV2 E Locking System (Electromechanical)	Page 11
6	Frame Routing Details	Page 12
6.1	F24 AV2 Keeps: Full Length	Page 12
6.2	F24 AV2 Keeps: Single Pocket	Page 13
6.3	F24 AV2 Keeps: One piece full length rounded end	Page 14
7	Sash Routing Details	Page 15
7.1	AV2 & AV2 E 20mm Face Plate	Page 15
7.2	AV2 & AV2 E 20mm Rounded End Face Plate	Page 16
7.3	AV2 & AV2 E 16mm Face Plate	Page 17

General
information

1
Fabrication
Procedures

2
Installation
Procedures

3
Operating
Instructions

4
Routine
Maintenance

5
Troubleshooting
Guides

6
Sash
Routing Details

7
Frame
Routing Details

1. Fabricator Manufacturing Procedure

1.1 Sash and Frame Preparation

1

Marking Out:

Mark out the hook housings, lock gear box and keep details either from the lock set itself or from the dimensioned drawing of the lock set.

2

Please refer to drawings 7.1, 7.2 or 7.3 on pages 15 - 17

Routing:

3

Carry out all routing for sash and frame hardware, prior to fabrication.
Completely remove all burrs and debris, prior to hardware installation.

Machining details:

4

Accurate machining and routing is essential for the AV2 / AV2-E locking mechanism.

Please refer to pages 12 or 17

5

1.2 Hardware installation

Lock

6

Position lock in Euro groove by assembling handle set and cylinder to sash, and secure lock to Euro groove with suitable fixing screws.

Installing door leaf into outer frame;

7

- I. Hang the door ensuring that a 4mm airgap is achieved, particularly to the lock to frame meeting stiles. **But do not allow the door to fully close until the keeps have been fitted.**
- II. Fit centre keep and individual keep pockets (centre line on lock faceplate should align with the lower edge of the centre latch strike).
[Please refer to drawings 6.1, 6.2 and 6.3 on pages 12 - 14.](#)
- III. Or, if full length keeps are being used, position centre keep, and butt the two extension keeps to it. Ensure that the frame is prepared to receive the striker plates for the two frame hook latches. These should end up flush with the inside edge of the outer frame.
- IV. Close/refit door sash

- V. Stand door set vertical and check adjustments and operation.
- VI. If machining and keep location is correct and therefore in the optimum position, keep adjustments should only be necessary on site to assist/fine tune door set installation.

1.3 Fabrication final checks and adjustments

Such checks can only be done with the door vertical, as the lock is reliant on the free movement of the gravity falling drive strip.

The latch keep, should be adjusted so that when the sash is firmly closed against the weather seal and latched, the hooks fall and throw fully automatically.

Adjust the keeps to ensure the hooks are fully thrown.

General information

1
Fabrication Procedures

2
Installation Procedures

3
Operating Instructions

4
Routine Maintenance

5
Troubleshooting Guides

6
Sash Routing Details

7
Frame Routing Details

2. Installation Procedure

2.1 Installation Set up

1

Plumb:

Check by using either a level or plumb line and a straight edge along both the lock and hinge sides. These two uprights should be straight, plumb and parallel.

2

Parallel:

Check by measuring the horizontal dimension across the top and bottom of the frame which should also measure the same.

3

Run up or Transit Blocks:

These should be removed during installation so as not to interfere with the natural slamming action of the door leaf.

4

Sash to Frame Trueness:

It is essential that the sash closes true to the outer frame, and thereby ensuring that the hooks fire simultaneously and that a level of weather performance is achieved.

5

This can be checked/adjusted by firstly opening the sash, then manually firing the hooks both top and bottom, by depressing the hook latches.

6

Then by closing the door sash too, checking that the top and bottom hook touch the outer frame at the same time. If one hook touches and the other not, then the outer frame fixings should be removed, the frame adjusted true to the sash and re-fixed so that they do.

7

2.2 Glazing, if applicable

Toeing and Heeling:

Ensure that the door is correctly toe and heeled so as to transmit the dead weight of the leaf back to the hinge side and eliminate the chance of the leaf sagging in the future.

Packing Opposite Hooks:

To achieve maximum security be sure to pack the glass adjacent to the locking points both lock and hinge side.

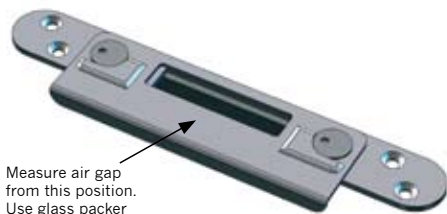

2.3 General Door Set up

Centre lines:

Sash to frame relationship of Lock to Centre Latch and hook keeps.

[Please refer to drawings 6.1, 6.2 and 6.3 on pages 12 - 14](#)

(Ensure that the datum line of the lock (located underneath the latch bolt) corresponds with the bottom edge of the latch bolt strike.)

Air Gap:

- On square edge doors:

Ensure that the gap between sash and frame, specifically on the Lock stile side, is parallel 4mm optimum, (with a tolerance of + 0, to – 1mm), and that the head also has a parallel air gap.

[Please see diagram above.](#)

- On rebated doors:

Open the door sash slightly so as to visually check that the clearance in between the sash and the edge of the outer frame/hook latch strike is 4mm optimum, (with a tolerance of + 0, to – 1mm).

Also, by drawing pencil lines around each of the corners of the leaf and adjacent to the locking points, ensure that the cover is consistent and within tolerance (check this dimension with the door supplier/manufacturer).

Cover:

The amount by which the outer frame is over lapped by the door leaf and should be consistent all round the leaf, [specifically on the lock stile side.](#)

2.4 Installation checks and Adjustments:

The latch keep, should be adjusted so that when the sash is firmly closed against the weather seal and latched, the hooks fall and throw fully.

The hook keep, should be adjusted so that when latched, the hooks are not quite touching the compression face of the hook adjuster plates. This can be checked by firstly ensuring that the hooks are fully thrown, and in fresh air, and then trying to force the sash open at both the hook positions.

If correctly adjusted the sash should not be able to be deflected in such a way, so as to not have contact with the weather seal.

General
information

1
Fabrication
Procedures

2
Installation
Procedures

3
Operating
Instructions

4
Routine
Maintenance

5
Troubleshooting
Guides

6
Sash
Routing Details

7
Frame
Routing Details

1

1. To Lock door just 'slamshut' (It is not necessary to lift the handle lever to lock the door as the hooks throw automatically).

2

2. Additional security can be achieved by turning the thumbturn or key. This throws an additional deadbolt and prevents the hooks being retracted from the outside if an outside lever has been fitted.*

5

6

3. From the inside to open the door pull lever down. This retracts the hooks and the sprung latch. (If the deadbolt has not been thrown).*

7

4. From the outside access can only be gained via the key. Turning the key retracts the hooks and the deadbolt (if thrown).*

Inside



Latch

Thumbturn



Outside



Fixed Pad

* AV2/AV2 E also available WITHOUT deadbolt.

3. Operating instructions

4. Routine Maintenance

Regular maintenance reduces costly remedial calls that you may have to attend to during the course of a year, therefore ensure that the end user is aware of the need to regularly clean and lubricate the locking mechanism and associated components. This can be done by using a light machine oil or silicon spray via the hook, dead bolt and latch apertures, at least twice a year or as the local environment requires.

General information

Fabrication Procedures **1**

Installation Procedures **2**

Operating Instructions **3**

4
Routine Maintenance

Troubleshooting Guides **5**

Sash Routing Details **6**

Frame Routing Details **7**

5. Trouble Shooting Guides

5.1 AV2 Locking System (Automatic/Manual)

Symptom	Fault	Remedial action reqd
Neither hook throws	Keep position incorrect	Reposition keeps
	Incorrect Air gap	Adjust air gap to 4mm, - 1mm, + 0
	Keep incorrectly adjusted	Adjust keeps (see installation guide)
	Drive strip jammed in open position	Ensure full free movement of drive strip
		Check that fore end fixing screws, are applied square and are not fouling the drive strip
Only one of the hooks throw	Frame not installed true to Sash	Adjust installation (see installation guide).
	Incorrect Air gap	Adjust air gap to 4mm, - 1mm, + 0
Latch bolt does not throw fully	Drive strip travel restricted downwards	Remove lock and check/adjust drive strip prep.
	Cylinder cam in wrong position	Check cylinder cam is in the conventional 5 or 7 o'clock position.
The door is stiff to open by key	Latch and hook keep not adjusted correctly	See installation guide and keep adjustments
	Drive strip travel restricted or fouled	Check that fore end fixing screws, are applied square and are not fouling the drive strip
	Drive strip free travel hindered	Check prep and clear of foreign material.
	Incorrect handle/cylinder prep	Correct offending prep/fixing
The hooks do not retract fully	Drive strip travel restricted upwards	Remove lock and check/adjust drive strip prep.

5. Trouble Shooting Guides

5.2 AV2 E Locking System (Electromechanical)

Symptom	Fault	Remedial action reqd
The motor is slow to retract the hooks	The correct size wire has not been used,	Refer to Operating manual for cable specification, Page 21
	Excessive cable run distances Keep incorrectly adjusted	Refer to Operating manual for max cable run lengths, Page 21. Adjust Keeps (see installation guide)
The motor tries but fails to retract the hooks	The lock is dead locked (if fitted) Keep incorrectly adjusted	Using the key in the cylinder, retract the dead bolt, and try again. Adjust Keeps (see installation guide)
The lock does not operate electrically	The motor connecting cable is not connected correctly to the motor unit	Remove lock and ensure that the connector is connected correctly, and that the pins are not bent (see drg)
	The system is not wired correctly	Refer to Operating manual for correct wiring diagrams, pages 21-25
	Frame not installed true to Sash	Adjust installation (see installation guide).
		Check against wiring diag and/or with a simple test circuit
	Incorrect sash to frame power transfer on hinge side	Check for damage and ensure pins connecting to frame part if applicable
	The correct size wire has not been used	Refer to Operating manual for cable specification, Page 21
	The power supply is incorrect/faulty	12 V DC stabilized, min 1 amp
	The switch has not been wired "potential free"	Wire switching device "voltage free"
	Short circuit of wiring	Carry out continuity test of all cores and cable runs. Check for glazing damage where applicable

Please note:

We strongly recommend that the lock be tested OUT of the door set, (mechanically, and electronically if applicable).

This should be done in conjunction with the End users Operation Guide, and will easily identify whether the lock, fabrication of the door set or installation is at fault, This will ensure that the quickest remedial action is taken.

General information

1
Fabrication Procedures

2
Installation Procedures

3
Operating Instructions

4
Routine Maintenance

5
Troubleshooting Guides

6
Sash Routing Details

7
Frame Routing Details

6. Frame Routing Details

6.1: F24 AV2 Keeps: Full Length (3 Piece)

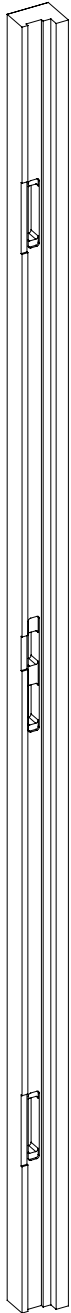
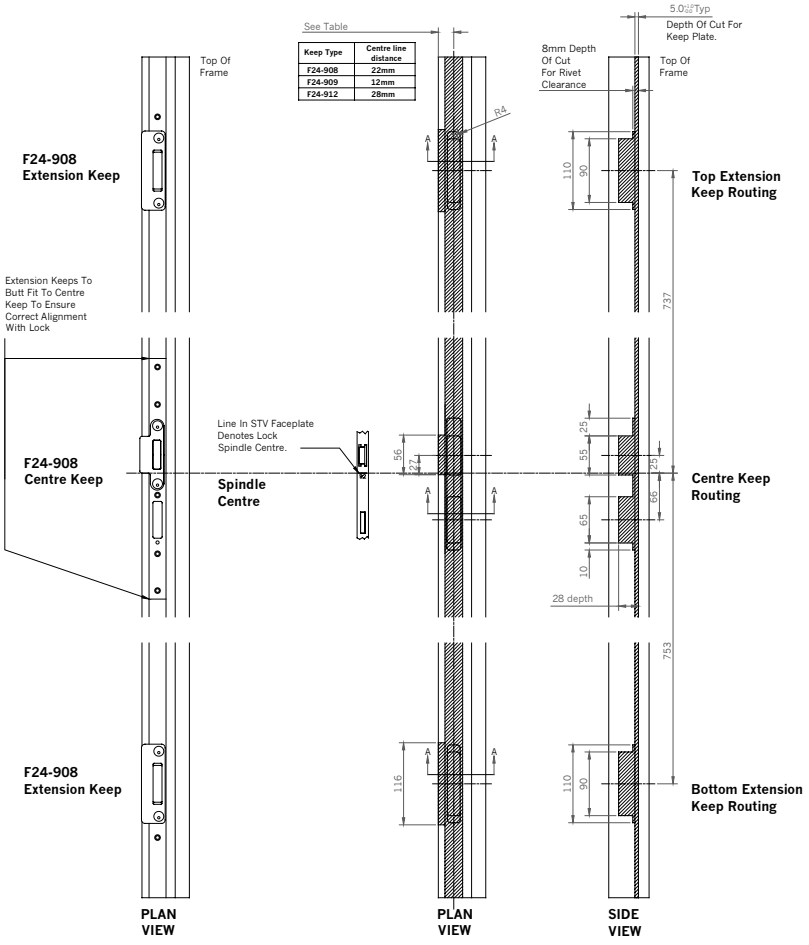

NOTE
Ensure That All Routing Material Is Cleared From Stile Before Fixing Lock.

Routing Details Based On Working Air Gap Of 4mm

 Denotes Routing

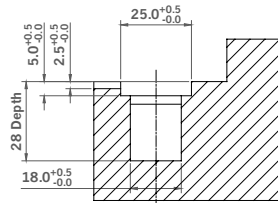

SECTION A-A

6.2: F24 AV2 Keeps: Single Pocket

F24-908
Rounded End Single
Pocket Keep

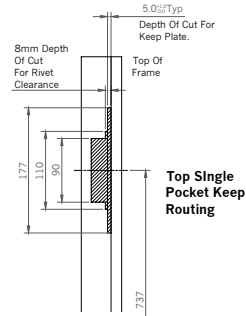
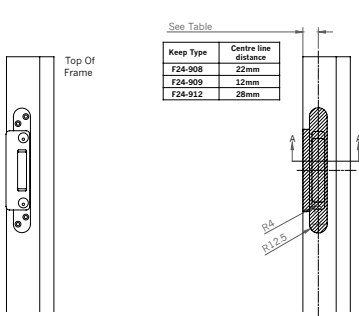

F24-908
Rounded End
Centre Keep

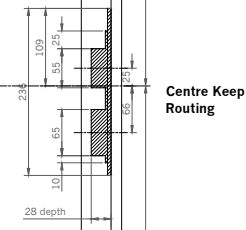
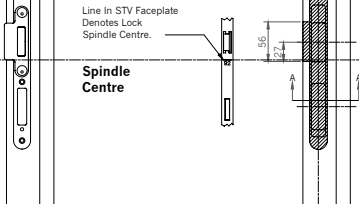

F24-908
Rounded End Single
Pocket Keep

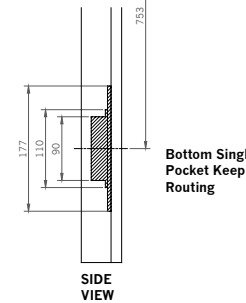
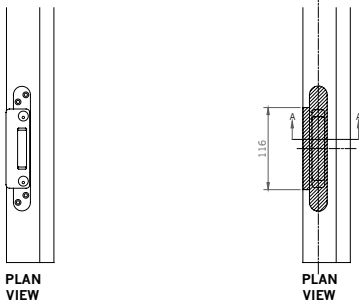

NOTE
Ensure That All Routing Material Is Cleared From Stile Before Fixing Lock.

Routing Details Based On Working Air Gap Of 4mm

Denotes Routing

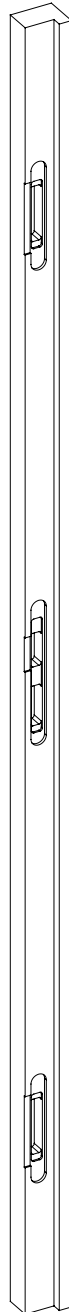
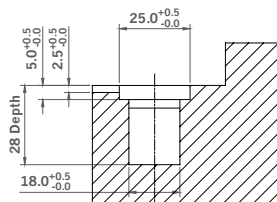

General information

Fabrication Procedures **1**

Installation Procedures **2**

Operating Instructions **3**

Routine Maintenance **4**

Troubleshooting Guides **5**

Sash Routing Details **6**

Frame Routing Details **7**

8

6.3: F24 AV2 Keeps: One Piece Full Length Rounded End

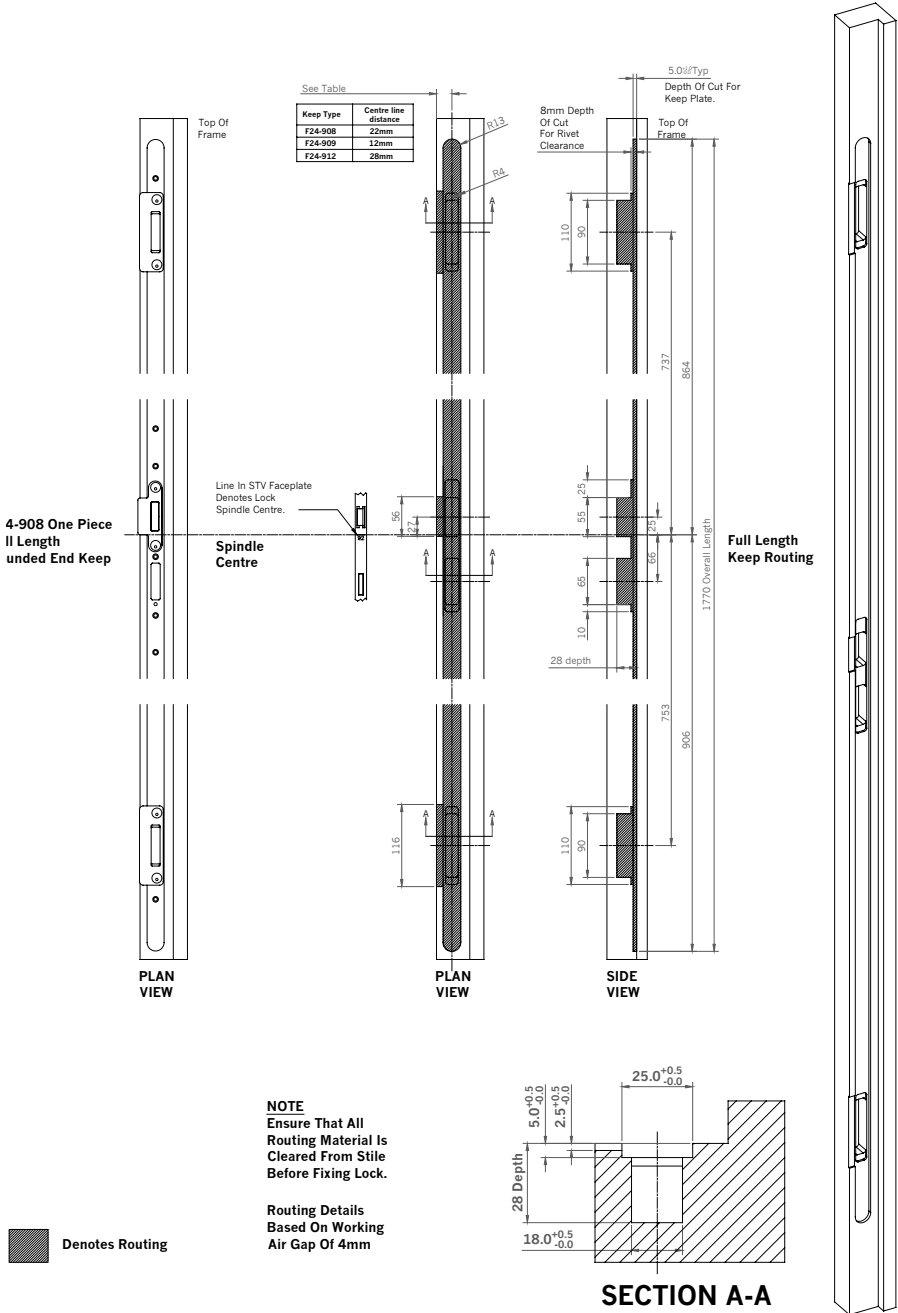

7. Sash Routing Details

7.1: AV2 & AV2 E 20mm Face Plate

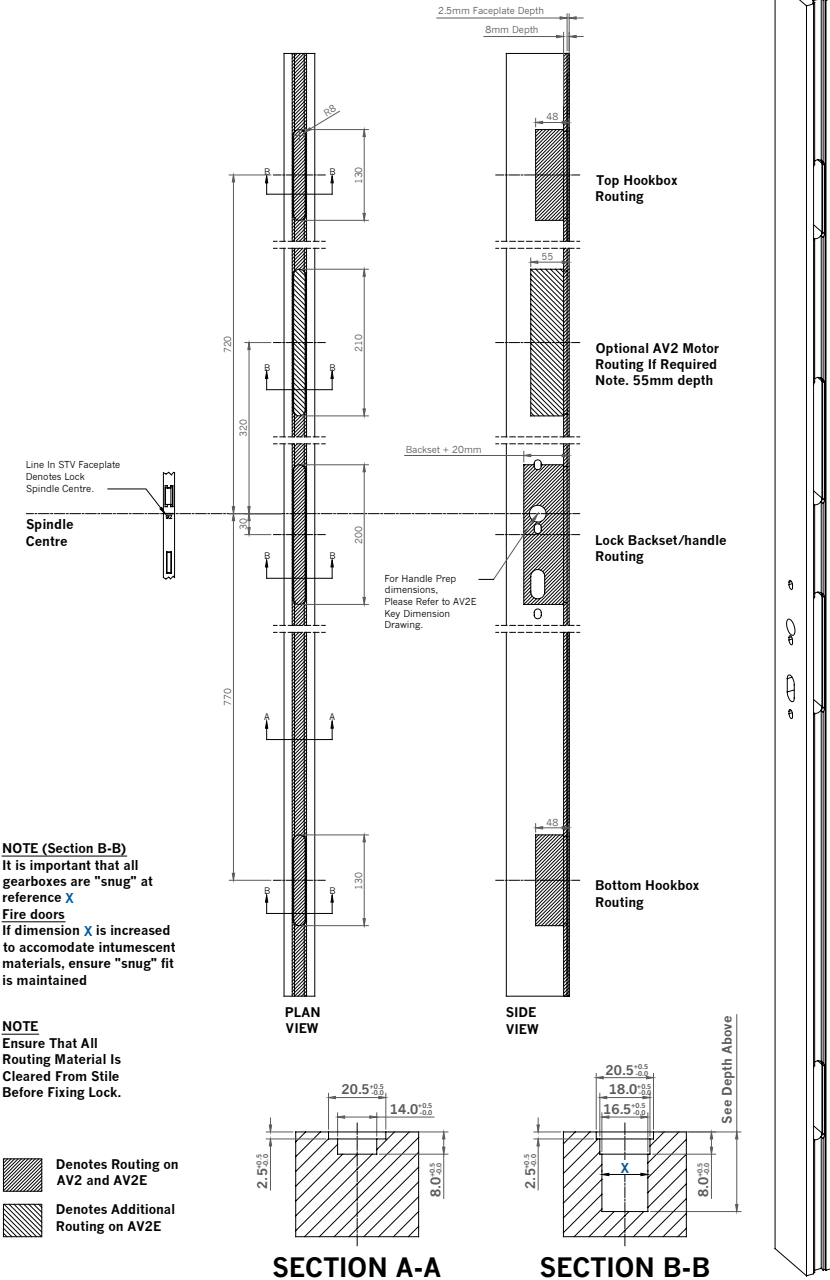

General information

Fabrication Procedures

Installation Procedures

Operating Instructions

Routine Maintenance

Troubleshooting Guides

Sash Routing Details

Frame Routing Details

1

2

3

4

5

6

7

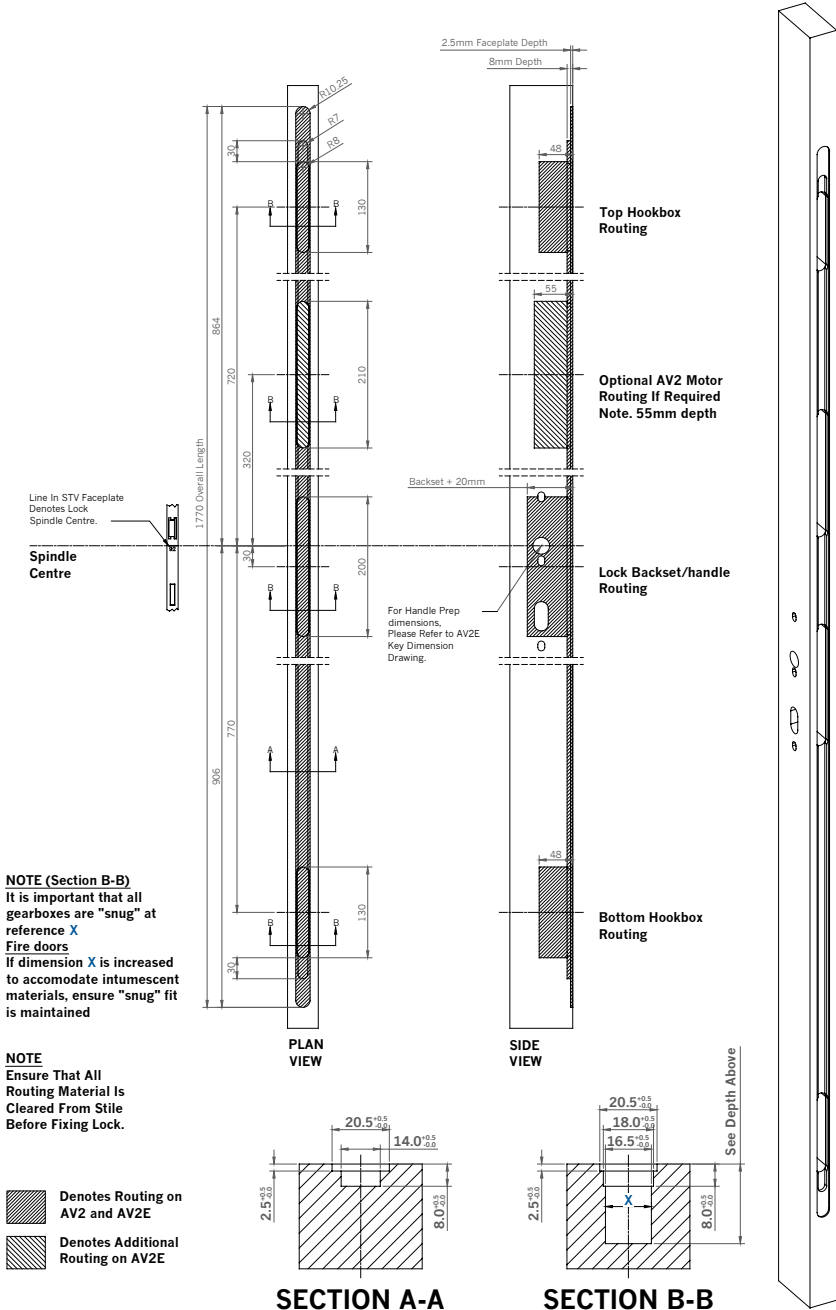

7.2: AV2 & AV2 E 20mm Rounded End Face Plate

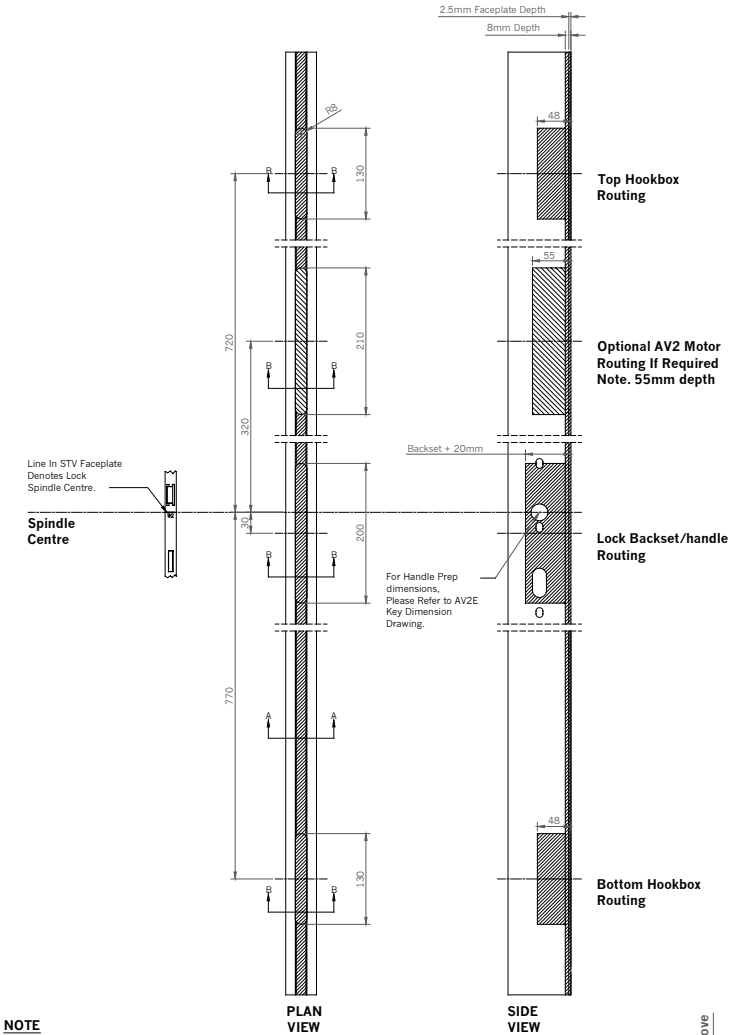

7.3: AV2 & AV2 E 16mm Face Plate Full Length



NOTE
Ensure That All Routing Material Is Cleared From Stile Before Fixing Lock.

-  Denotes Routing on AV2 and AV2E
-  Denotes Additional Routing on AV2E

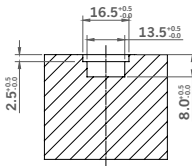

SECTION A-A

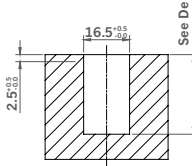

SECTION B-B

See Depth Above

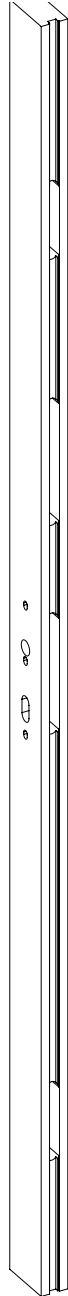

General information

Fabrication Procedures **1**

Installation Procedures **2**

Operating Instructions **3**

Routine Maintenance **4**

Troubleshooting Guides **5**

Sash Routing Details **6**

Frame Routing Details **7**

EC Declaration of Conformity

For the products:

Electronic Automatic Locking System

in the design:

Safety door locking system AV2 + motor control EAV 1 (mounted/not mounted)

we shall hereby certify that they conform to the requirements and directives established and stipulated by the Council on the Harmonization of Legal Regulations of Member States regarding Electromagnetic compatibility of the product:

Emitted interference according to: EN 61000 - 6 - 3

Immunity to interference according to: EN 6100 - 6 - 2

This declaration is made on behalf of the manufacturer:

Winkhaus STV GmbH & Co. KG

Berkeser Str. 6

D-98617 Meiningen

Germany

and authorized by:

Meiningen, 09 July 2004

A handwritten signature in black ink, appearing to be 'D. Winkhaus', is written over the 'and authorized by:' text.

Notes:

Winkhaus UK Ltd

2950 Kettering Parkway, Kettering,
Northants NN15 6XZ
Tel: +44 (0)1536 316091
Fax: +44 (0)1536 419091

www.winkhaus.co.uk
email: enquiries@winkhaus.co.uk